



MS5525DSO

(Digital Small Outline)

SPECIFICATIONS

- **Integrated Digital Pressure Sensor**
(24-bit $\Delta\Sigma$ ADC)
- **Fast Conversion Down to 1 ms**
- **Low Power, 1 μA (standby < 0.15 μA)**
- **Supply Voltage: 1.8 to 3.6V**
- **Pressure Range: 1 to 30 PSI**
- **I²C and SPI Interface**

FEATURES

- Small Outline IC Package
- Barbed Pressure Ports
- Low Power, High Resolution ADC
- Digital Pressure and Temperature Outputs

APPLICATIONS

- Factory Automation
- Altitude and Airspeed Measurements
- Medical Instruments
- Leak Detection

The MS5525DSO is a new generation of Digital Small Outline pressure sensors from MEAS with SPI and I²C bus interface designed for high volume OEM users. The sensor module includes a pressure sensor and an ultra-low power 24-bit $\Delta\Sigma$ ADC with internal factory calibrated coefficients. It provides a 24-bit digital pressure and temperature value and different operation modes that allow the user to optimize for conversion speed and current consumption. The MS5525DSO can be interfaced to virtually any microcontroller. The communication protocol is simple, without the need of programming internal registers in the device.

This new sensor module generation is based on leading MEMS technology and latest benefits from TE proven experience and know-how in high volume manufacturing of pressure modules, which have been widely used for over a decade.

The rugged engineered thermoplastic transducer is available in single and dual port configurations, and can measure absolute, gauge, compound, and differential pressure from 1 to 30psi.

STANDARD RANGES (PSI)

FS Pressure	Absolute	Gauge	Differential
001			DB, SB,ST, DH
002		DB, SB, ST, DH,FT	DB, SB,ST, DH
005		DB, SB, ST, DH,FT	DB, SB,ST ,DH
015	DB, FB, DH, FT	DB, SB, ST, DH,FT	DB, DH
030	DB, FB, DH, FT	DB, SB, ST, DH,FT	DB, DH

See Package Configurations: DB= Dual Barb, DH= Dual Hole, SB=Single Barb, ST=Single Tube, FT=Front Side Tube, FB=Front Single Barb

ABSOLUTE MAXIMUM RATING

Parameter	Conditions	Min	Max	Unit	Symbol/Notes
Supply Voltage	T _A = 25°C	-0.3	3.6	V	V _{DD}
Storage Temperature		-40	125	°C	
Overpressure	T _A = 25 °C, both Ports		60	psi	
Burst Pressure	T _A = 25 °C, Port 1			psi	See Table 1
ESD	HBM	-4	+4	kV	EN 61000-4-2
Solder Temperature		250°C, 5 sec max.			

Table 1- BURST PRESSURE BY RANGE AND PORT DESIGNATION.

Range	Port 1	Port 2	Unit
001	10	10	psi
002	20	20	psi
005	50	15	psi
015	120	60	psi
030	120	120	psi

ENVIRONMENTAL SPECIFICATIONS

Parameter	Conditions
Mechanical Shock	Mil Spec 202F, Method 213B, Condition C, 3 Drops
Mechanical Vibration	Mil Spec 202F, Method 214A, Condition 1E, 1Hr Each Axis
Thermal Shock	100 Cycles over Storage Temperature, 30 minute dwell
Life	1 Million FS Cycles
MTTF	>10Yrs, 70 °C, 10 Million Pressure Cycles, 120%FS Pressure
MSL	Moisture Sensitivity Level is 3

PERFORMANCE SPECIFICATIONS

Unless otherwise specified: Supply Voltage¹ 3.0 V_{DC}, Reference Temperature: 25°C

PARAMETERS	MIN	TYP	MAX	UNITS	NOTES
Operating Voltage	1.8		3.6		
ADC			24	bits	
Pressure Accuracy	See Table 2 Below			%FS	2,5
Total Error Band (TEB)	-2.5		2.5	%FS	3
Temperature Accuracy (Reference Temperature)		±1.5		°C	4,5
Temperature Accuracy		±2.5		°C	4,5
Supply Current	See OSR Table Below			mA	
Compensated Temperature	0		85	°C	
Operating Temperature	-40		+125	°C	
Conversion Time	See OSR Table Below			ms	
Weight		3		grams	

Media Non-Corrosive Dry Gases Compatible with Silicon, Glass, LCP, RTV, Gold, Thermo-Epoxy, Silicone Gel, Aluminum and Epoxy. See "Wetted Material by Port Designation" chart.

Notes

- Proper operation requires an external capacitor placed as shown in Application Circuit. Output is not ratiometric to supply voltage.
- The maximum deviation from a best fit straight line (BFSL) fitted to the output measured over the pressure range at 25°C. Includes all errors due to pressure non-linearity, hysteresis, and non-repeatability.
- The maximum deviation from ideal output with respect to input pressure and temperature over the compensated temperature range. Total error band (TEB) includes all accuracy errors, thermal errors over the compensated temperature range, span and offset calibration tolerances. TEB values are valid only at the calibrated supply voltage.
- The deviation from a best fit straight line (BFSL) from 25°C. to 85°C.
- Six coefficients must be read by microcontroller software and are used in a mathematical calculation for converting D1 and D2 into compensated pressure and temperature values.

Table 2- TYPICAL ACCURACY SPECIFICATION BY PRESSURE RANGE

Range	Port 1	Port 2	Unit
001	±0.25	±1.0	%FSS
002	±0.25	±0.5	%FSS
005	±0.50	±1.0	%FSS
015	±0.25	±0.25	%FSS
030	±0.25	±0.25	%FSS

OVERSAMPLING RATIO (OSR) PERFORMANCE CHARACTERISTICS

SUPPLY CURRENT CHARACTERISTICS

Parameter	Symbol	Conditions	Min.	Typ.	Max	Unit
Supply current (1 sample per sec.)	I _{DD}	OSR 4096		12.5		μA
		2048		6.3		
		1024		3.2		
		512		1.7		
		256		0.9		
Peak supply current		during conversion		1.4		mA
Standby supply current		at 25°C		0.02	0.14	μA

ANALOG DIGITAL CONVERTER (ADC)

Parameter	Symbol	Conditions	Min.	Typ.	Max	Unit
Conversion time	t _c	OSR 4096	7.40	8.22	9.04	ms
		2048	3.72	4.13	4.54	
		1024	1.88	2.08	2.28	
		512	0.95	1.06	1.17	
		256	0.48	0.54	0.60	

INPUT/OUTPUT SPECIFICATIONS

DIGITAL INPUTS (CSB, I²C, DIN, SCLK)

Parameter	Symbol	Conditions	Min.	Typ.	Ma	Unit
Serial data clock	SCLK	SPI protocol			2	MHz
Serial data clock	SCL	I ² C protocol			400	kHz
Input high voltage	V _{IH}	Pins CSB	80%		100% V _{DD}	V
Input low voltage	V _{IL}		0%		20% V _{DD}	V
Input leakage current	I _{leak25°C}	at 25°C			0.1	μA
	I _{leak85°C}				5	
Input capacitance	C _{IN}				6	pF

PRESSURE OUTPUTS (I²C, DOUT)

Parameter	Symbo	Conditions	Min.	Ty	M	Unit
Output high voltage	V _{OH}	I _{source} = 0.6 mA	80% V _{DD}		100%	V
Output low voltage	V _{OL}	I _{sink} = 0.6 mA	0% V _{DD}		20% V _{DD}	V
Load capacitance	C _{LOAD}				1	pF

FUNCTIONAL DESCRIPTION

GENERAL

The MS5525DSO consists of a piezo-resistive sensor and a sensor interface IC. The main function of the MS5525DSO is to convert the uncompensated analog output voltage from the piezo-resistive pressure sensor to a 24-bit digital value, as well as providing a 24-bit digital value for the temperature of the sensor.

FACTORY CALIBRATION

Every module is individually factory calibrated at two temperatures and three pressures. As a result, six coefficients necessary to compensate for process variations and temperature variations are calculated and stored in the 128-bit PROM of each module. These bits, partitioned into six coefficients, C1 through C6, must be read by the microcontroller software and used in the program converting D1 and D2 into compensated pressure and temperature values.

The coefficients C0 and C7 are for factory calibration and CRC.

SERIAL INTERFACE

The MS5525DSO has built in two types of serial interfaces: SPI and I²C. Pulling the Protocol Select pin PS to low selects the SPI protocol, pulling PS to high activates the I²C bus protocol.

Pin PS	Mode	Pins used
High	I ² C	SDA, SCL CSB
Low	SPI	SDI, SDO, SCLK, CSB

SPI MODE

The external microcontroller clocks in the data through the input SCLK (Serial CLock) and SDI (Serial Data In). In the SPI mode module can accept both mode 0 and mode 3 for the clock polarity and phase. The sensor responds on the output SDO (Serial Data Out). The pin CSB (Chip Select) is used to enable/disable the interface, so that other devices can talk on the same SPI bus. The CSB pin can be pulled high after the command is sent or after the end of the command execution (for example end of conversion). The best noise performance from the module is obtained when the SPI bus is idle and without communication to other devices during the ADC conversion.

I²C MODE & ADDRESSING

The external microcontroller clocks in the data through the input SCL (Serial CLock) and SDA (Serial Data). The sensor responds on the same pin SDA which is bidirectional for the I²C bus interface. So this interface type uses only 2 signal lines and does not require a chip select, which can be favorable to reduce board space. In I²C -Mode the complement of the pin CSB (Chip Select) represents the LSB of the I²C address. It is possible to use two sensors with two different addresses on the I²C bus. The pin CSB must be connected to VDD or GND do not leave these pins unconnected.

Pin CSB	Address (7 bits)
High	0x76
Low	0x77

COMMANDS

The MS5525DSO has only five basic commands:

1. Reset
2. Read PROM (128 bit of calibration words)
3. D1 conversion
4. D2 conversion
5. Read ADC result (24 bit pressure / temperature)

Size of each command is 1 byte (8 bits) as described in the table below. After ADC read commands the device will return 24 bit result and after the PROM read 16bit result. The address of the PROM is embedded inside of the PROM read command using the Ad2, Ad1 and Ad0 bits.

Bit number	Command byte								hex value
	0	1	2	3	4	5	6	7	
Bit name	PRM	COV	-	Typ	Ad2/ Os2	Ad1/ Os1	Ad0/ Os0	Stop	
Command									
Reset	0	0	0	1	1	1	1	0	0x1E
Convert D1 (OSR=256)	0	1	0	0	0	0	0	0	0x40
Convert D1 (OSR=512)	0	1	0	0	0	0	1	0	0x42
Convert D1 (OSR=1024)	0	1	0	0	0	1	0	0	0x44
Convert D1 (OSR=2048)	0	1	0	0	0	1	1	0	0x46
Convert D1 (OSR=4096)	0	1	0	0	1	0	0	0	0x48
Convert D2 (OSR=256)	0	1	0	1	0	0	0	0	0x50
Convert D2 (OSR=512)	0	1	0	1	0	0	1	0	0x52
Convert D2 (OSR=1024)	0	1	0	1	0	1	0	0	0x54
Convert D2 (OSR=2048)	0	1	0	1	0	1	1	0	0x56
Convert D2 (OSR=4096)	0	1	0	1	1	0	0	0	0x58
ADC Read	0	0	0	0	0	0	0	0	0x00
PROM Read	1	0	1	0	Ad2	Ad1	Ad0	0	0xA0 to 0xAE

Figure 1: Command structure

Start
5525DSO-pp005GS Example
 $T_{min}=-40^{\circ}\text{C}$, $T_{max}=125^{\circ}\text{C}$

Read Calibration Data from PROM

Variable	Coefficient Description	Recommended Variable Type	Size ^[1]	Value		Example/ Typical
			[Bit]	Min	Max	
C1	Pressure Sensitivity SENS_{T1}	unsigned int 16	16	0	65535	36402
C2	Pressure Offset OFF_{T1}	unsigned int 16	16	0	65535	39473
C3	Temperature Coefficient of Pressure Sensitivity TCS	unsigned int 16	16	0	65535	40393
C4	Temperature Coefficient of Pressure Offset TCO	unsigned int 16	16	0	65535	29523
C5	Reference Temperature T_{REF}	unsigned int 16	16	0	65535	29854
C6	Temperature Coefficient of Temperature TEMPSENS	unsigned int 16	16	0	65535	21917

Read Digital Pressure and Temperature Data

D1	Digital Pressure Value	unsigned int 32	24	0	16777216	5240585
D2	Digital Temperature Value	unsigned int 32	24	0	16777216	3869265

Calculate Temperature

dT	Difference between actual and reference temperature $dT = D2 - T_{REF} = D2 - C5 * 2^{Q5}$	signed int 32	25	-16776960	16777216	47953
TEMP	Measured temperature $\text{TEMP} = 20^{\circ}\text{C} + dT * \text{TEMPSENS} = 2000 + dT * C6 / 2^{Q6}$	signed int 32	41	-4000	12500	2501 =25.01 °C

Calculate Temperature Compensated Pressure

OFF	Offset at actual temperature $\text{OFF} = \text{OFF}_{T1} + \text{TCO} * dT = C2 * 2^{Q2} + (C4 * dT) / 2^{Q4}$	signed int 64	41			5218046194
SENS	Sensitivity at actual temperature $\text{SENS} = \text{SENS}_{T1} + \text{TCS} * dT = C1 * 2^{Q1} + (C3 * dT) / 2^{Q3}$	signed int 64	41			2415906558
P	Temperature Compensated Pressure $P = D1 * \text{SENS} - \text{OFF} = (D1 * \text{SENS} / 2^{21} - \text{OFF}) / 2^{15}$	signed int 32	61			24996 =2.4996psi

Display Pressure and Temperature Value

Figure 2: Flow chart for pressure and temperature reading and software compensation.

Qx Coefficients Matrix by Pressure Range

Part Number	Pmin	Pmax	Q1	Q2	Q3	Q4	Q5	Q6	T _{RES} (°C)	P _{RES} (PSI)
5525DSO-pp001DS	-1	1	15	17	7	5	7	21	0.01	0.0001
5525DSO-pp002GS	0	2	14	16	8	6	7	22	0.01	0.0001
5525DSO-pp002DS	-2	2	16	18	6	4	7	22	0.01	0.0001
5525DSO-pp005GS	0	5	16	17	6	5	7	21	0.01	0.0001
5525DSO-pp005DS	-5	5	17	19	5	3	7	22	0.01	0.0001
5525DSO-pp015GS	0	15	16	17	6	5	7	22	0.01	0.0001
5525DSO-pp015AS	0	15	16	17	6	5	7	22	0.01	0.0001
5525DSO-pp015DS	-15	15	17	19	5	3	7	22	0.01	0.0001
5525DSO-pp030AS	0	30	17	18	5	4	7	22	0.01	0.0001
5525DSO-pp030GS	0	30	17	18	5	4	7	22	0.01	0.0001
5525DSO-pp030DS	-30	30	18	21	4	1	7	22	0.01	0.0001

MEMORY MAPPING

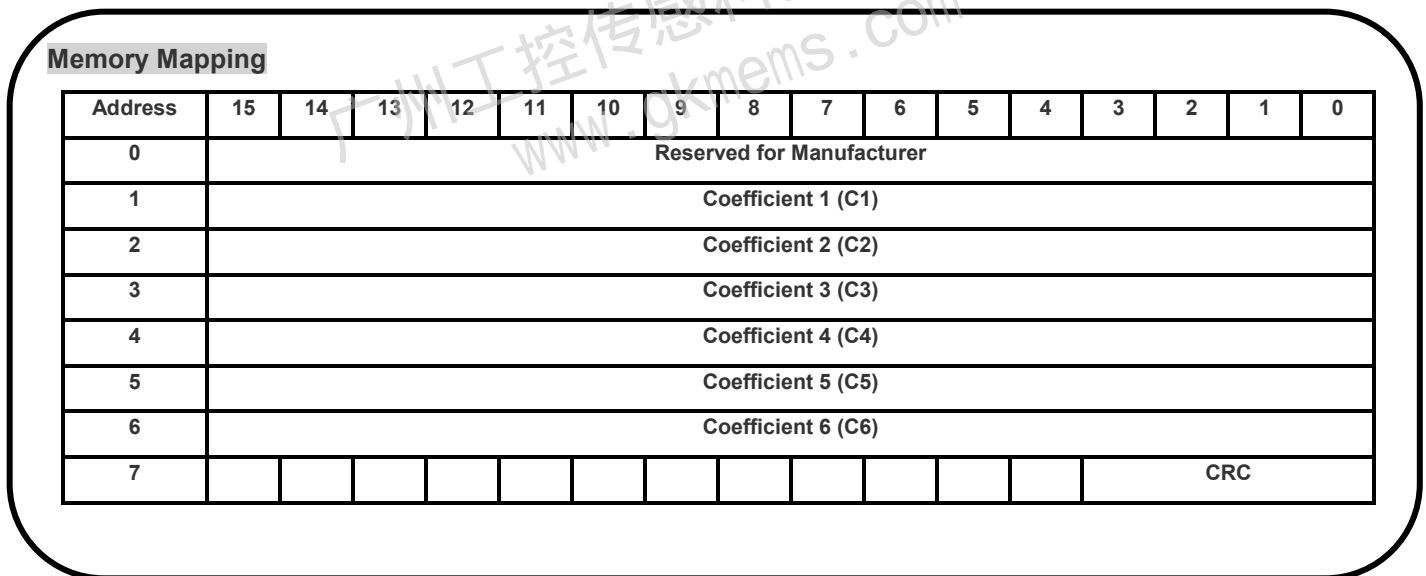

Figure 3: Memory PROM Mapping

Notes

[1] Maximal size of intermediate result during evaluation of variable.

SPI INTERFACE

RESET SEQUENCE

The Reset sequence shall be sent once after power-on to make sure that the calibration PROM gets loaded into the internal register. It can be also used to reset the device ROM from an unknown condition

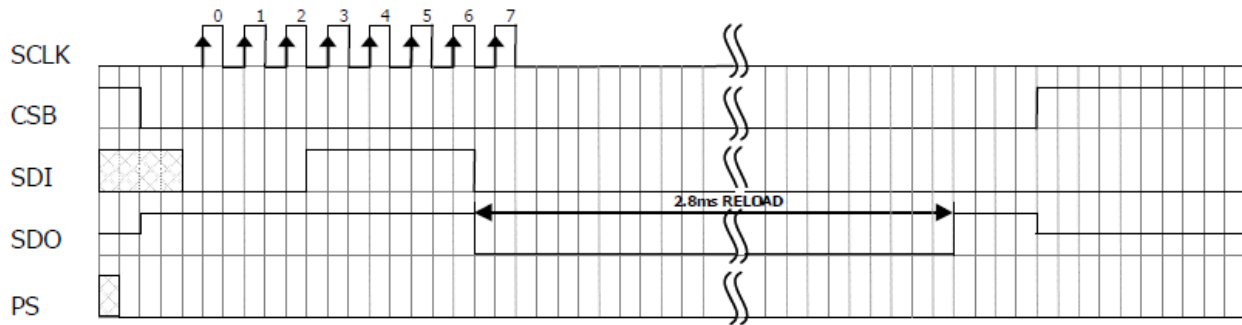

Figure 5: Reset command sequence SPI mode 0

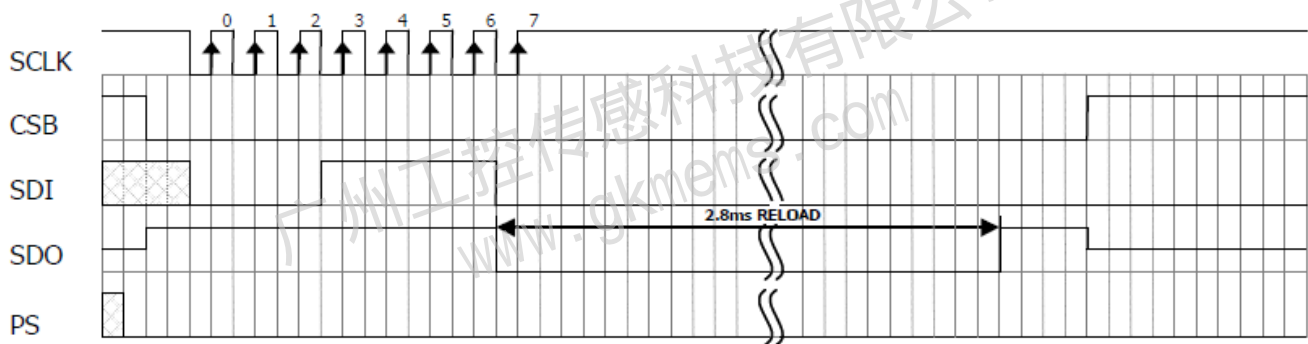

Figure 6: Reset command sequence SPI mode 3

CONVERSION SEQUENCE

The conversion command is used to initiate uncompensated pressure (D1) or uncompensated temperature (D2) conversion. The chip select can be disabled during this time to communicate with other devices. After the conversion, using ADC read command the result is clocked out with the MSB first. If the conversion is not executed before the ADC read command, or the ADC read command is repeated, it will give 0 as the output result. If the ADC read command is sent during conversion the result will be 0, the conversion will not stop and the final result will be wrong. Conversion sequence sent during the already started conversion process will yield incorrect result as well.

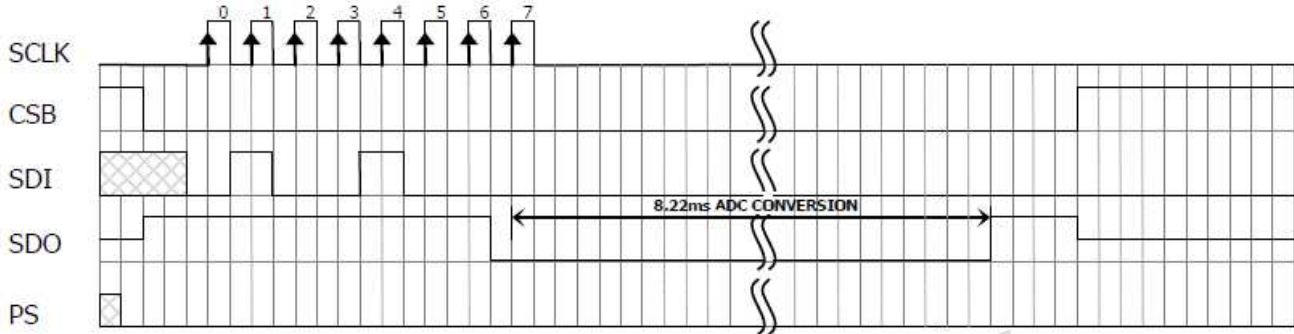

Figure 7: Conversion out sequence, Typ=d1, OSR = 4096

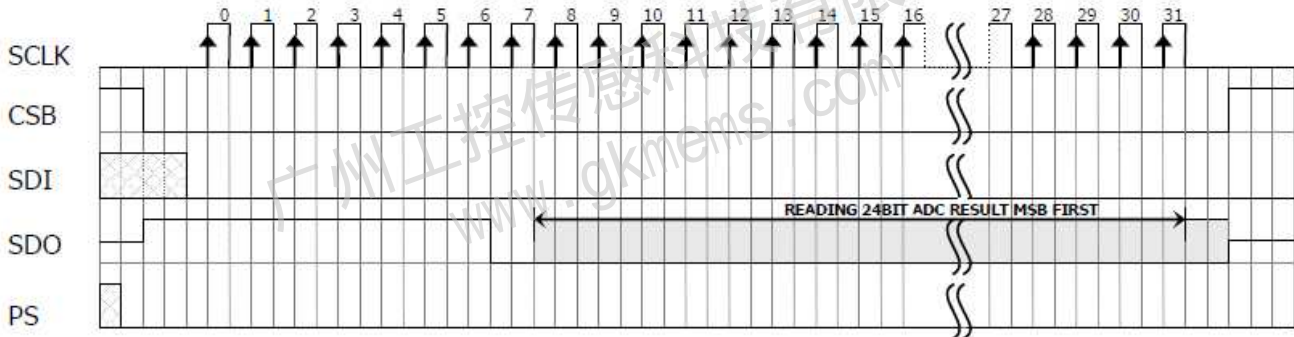

Figure 8: ADC Read sequence

PROM READ SEQUENCE

The read command for PROM shall be executed once after reset by the user to read the content of the calibration PROM and to calculate the calibration coefficients. There are in total 8 addresses resulting in a total memory of 128 bit. Address 0 contains factory data and the setup, addresses 1-6 calibration coefficients and address 7 contains the serial code and CRC. The command sequence is 8 bits long with a 16 bit result which is clocked with the MSB first.

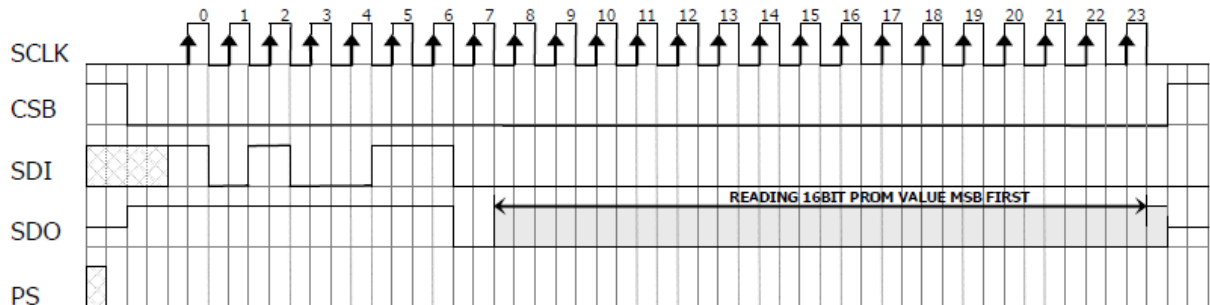

Figure 9: PROM Read sequence, address = 011 (Coefficient 3).

I²C INTERFACE

COMMANDS

Each I²C communication message starts with the start condition and it is ended with the stop condition. The MS5525DSO address is 111011Cx, where C is the complementary value of the pin CSB. Since the IC does not have a microcontroller inside, the commands for I²C and SPI are quite similar.

RESET SEQUENCE

The reset can be sent at any time. In the event that there is not a successful power on reset this may be caused by the SDA being blocked by the module in the acknowledge state. The only way to get the MS5525DSO to function is to send several SCLKs followed by a reset sequence or to repeat power on reset.

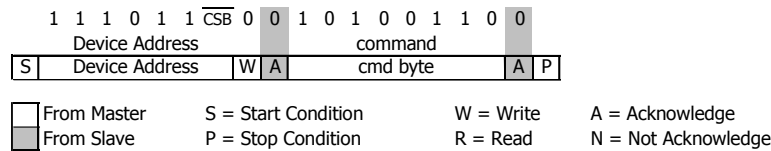

Figure 10: I2C Reset Command

PROM READ SEQUENCE

The PROM Read command consists of two parts. First command sets up the system into PROM read mode. The second part gets the data from the system.

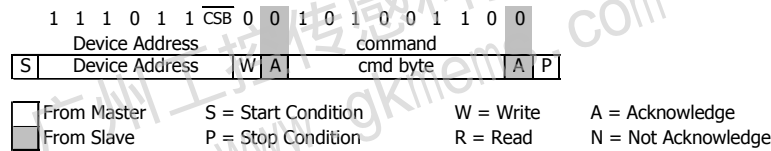

Figure 11: I2C Command to read memory address= 011 (Coefficient 3)

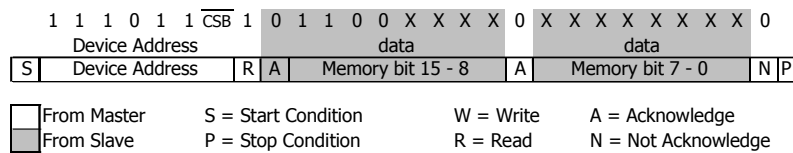

Figure 12: I2C response from MS5525DSO

CONVERSION SEQUENCE

A conversion can be started by sending the command to MS5525DSO. When command is sent to the system it stays busy until conversion is done. When conversion is finished the data can be accessed by sending a Read command, when an acknowledge appears from the MS5525DSO, 24 SCLK cycles may be sent to receive all result bits. Every 8-bit the system waits for an acknowledge signal.

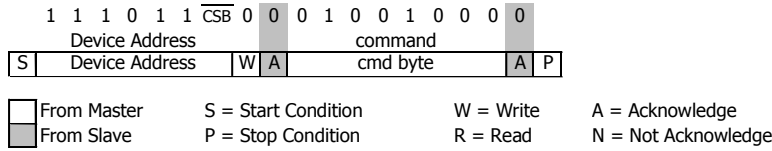

Figure 13: I²C Command to initiate a pressure conversion (OSR=4096, typ=D1)

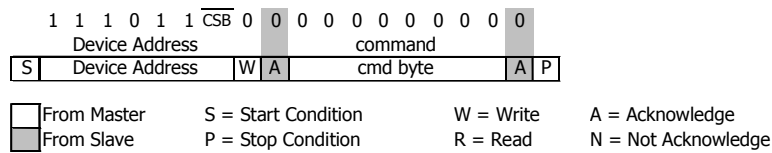

Figure 14: I²C ADC read sequence

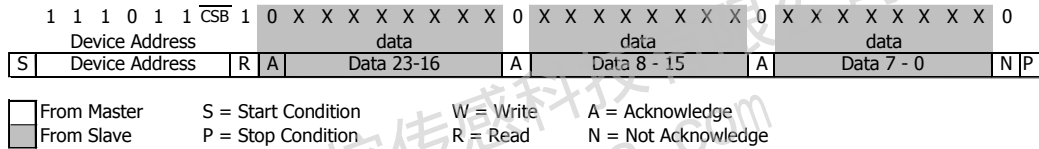
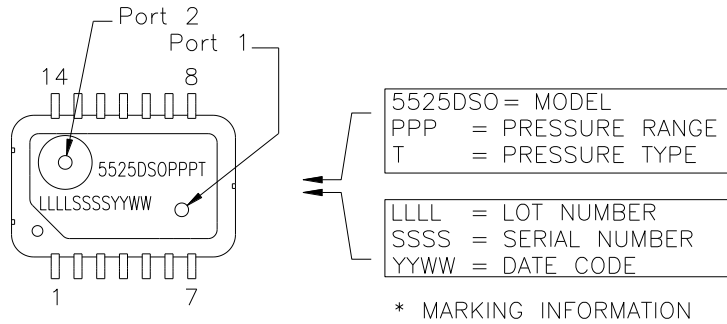

Figure 15: I²C response from MS5525DSO

CYCLIC REDUNDANCY CHECK (CRC)

MS5525DSO contains a PROM memory with 128-Bit. A 4-bit CRC has been implemented to check the data validity in memory. The application note AN520 describes in detail CRC-4 code used.

MARKING, AND PRESSURE TYPE CONFIGURATION



Pressure Type	Pmin	Pmax	Description
Absolute	0psiA	+Prange	Output is proportional to the difference between 0psiA (Pmin) and pressure applied to Port 1.
Differential/ Bidirectional	-Prange	+Prange	Output is proportional to the difference between Port 1 and Port 2. Output swings positive when Port 2 > Port 1. Output is 50% of total counts when Port 1 = Port 2.
Gauge	0psiG	+Prange	Output is proportional to the difference between 0psiG (Pmin) and Port 1. Output swings positive when Port 2 > Port 1.

WETTED MATERIAL BY PORT DESIGNATION

Material Style	Port	LCP	Thermo-Epoxy Resin	Epoxy	RTV	Glass	Silicon	Silicone Gel
All	Port 1	X	X	X				X
	Port 2	X	X	X	X	X	X	

"X" Indicates Wetted Materials

PINOUT DESIGNATION

Pin Name	Pin	Function	
		I ² C	SPI
SIN-	1,3	Sensor Input, Negative	Sensor Input, Negative
SOUT-	2,4	Sensor Outputs, Negative	Sensor Outputs, Negative
SDO	5	Not Applicable	Serial Data Output
SDA/SDI	6	I ² C Data Input and Output	SPI Serial Data Input
SCL/SCLK	7	I ² C Clock	SPI Clock
CSB	8	Defines I ² C Address	Chip Select (Active Low)
Supply -	9	Return Supply Voltage	Return Supply Voltage
PS	10	Protocol Select	
		PS = (VDD)	PS = (GND)
		I ² C Protocol Selected	SPI Protocol Selected
		CSB= (VDD) I ² C Address = 1110110X (0xEC, 0xED)	
		CSB= (GND) I ² C Address = 1110111X (0xEE, 0xEF)	
Supply +	11,13	Positive Supply Voltage	Positive Supply Voltage
SOUT+	12,14	Sensor Outputs, Positive	Sensor Outputs, Positive

BLOCK DIAGRAM

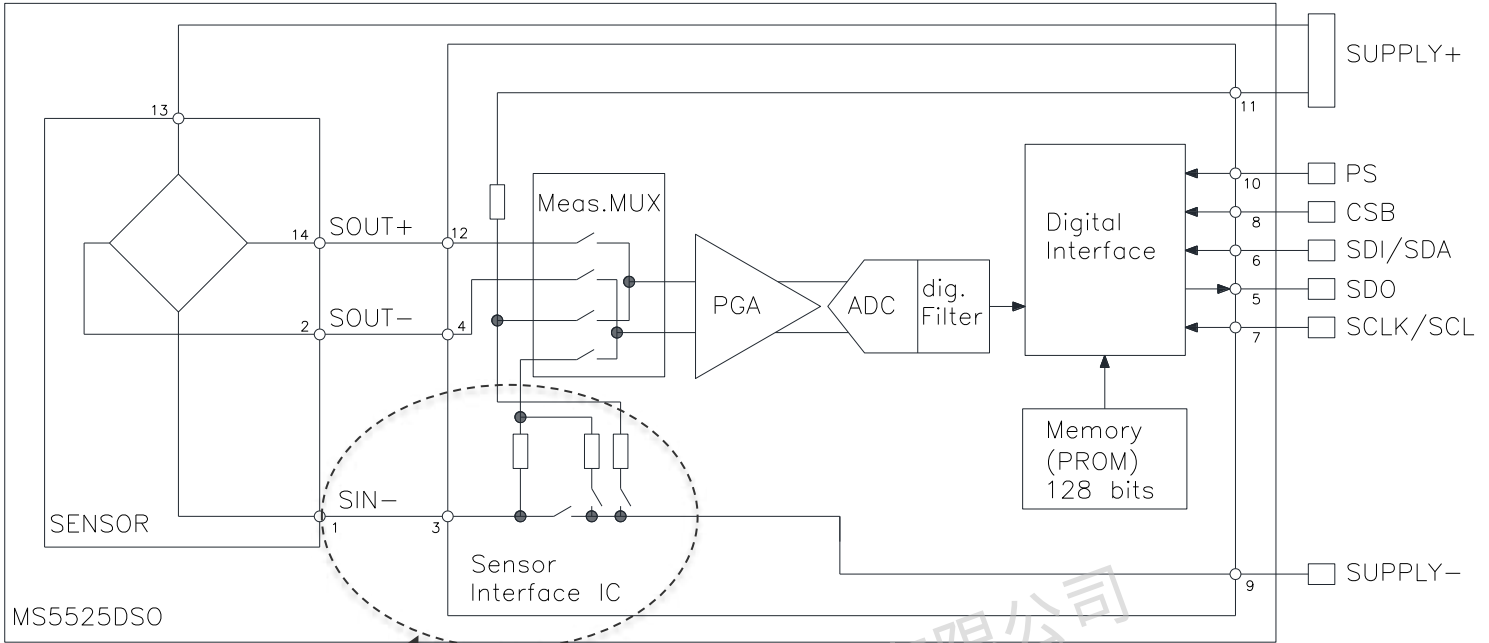

Figure 4: Block diagram of MS5525DSO

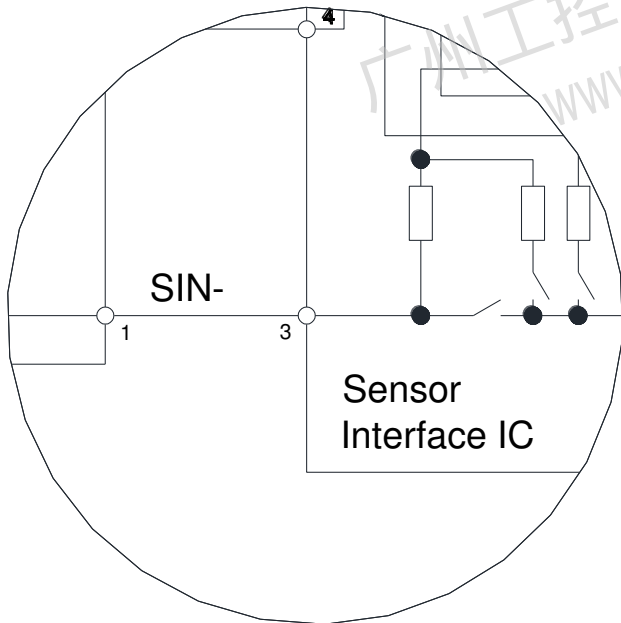

Figure 5: SIN- Pins 1 and 3 of MS5525DSO

NOTE:

DO NOT CONNECT SIN- to SUPPLY-

This will short the internal switch within the sensor interface IC resulting in a disruption of the temperature measurements.

Table B

Pad No.	Function	Notes
1	SIN-	Connect to Pin 3
2	SOUT-	Connect to Pin 4
3	SIN-	Connect to Pin 1
4	SOUT-	Connect to Pin 2
5	SDO	
6	SDI/SDA	
7	SCLK/SCL	
8	CSB	
9	SUPPLY-	
10	PS	
11	SUPPLY+	Connect to Pin 13
12	SOUT+	Connect to Pin 14
13	SUPPLY+	Connect to Pin 11
14	SOUT+	Connect to Pin 12

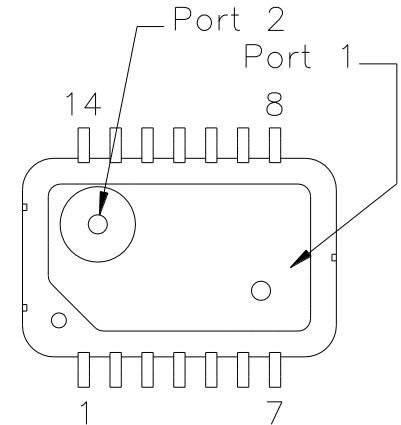

Notes:

[1] Function pins that share the same name (SOUT+, SOUT-, SIN-, SUPPLY+) must be connected on the PCB for proper operation, as described in the 'Notes' column of Table B.

[2] Must place a 0.1µf decoupling capacitor between VDD and GND on PCB and as close as possible to sensor.

RECOMMEND PCB LAYOUT

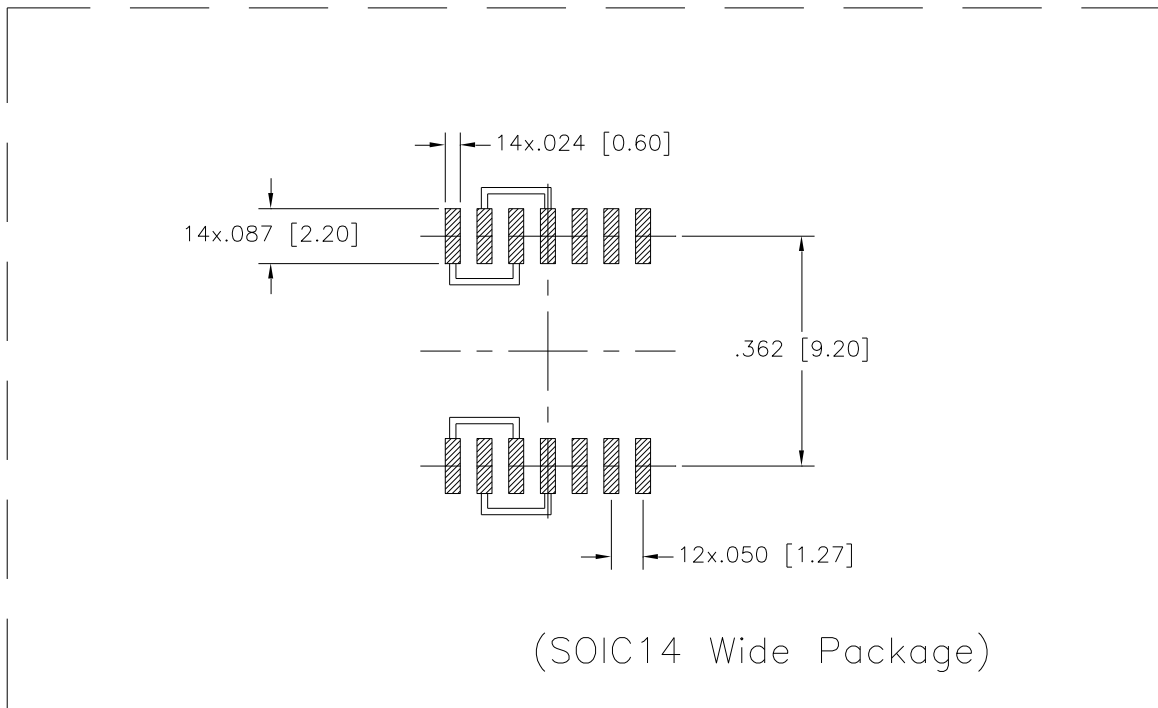

APPLICATION CIRCUIT

The MS5525DSO is a circuit that can be used in conjunction with a microcontroller. It is designed for low-voltage systems with a supply voltage of 3 V.

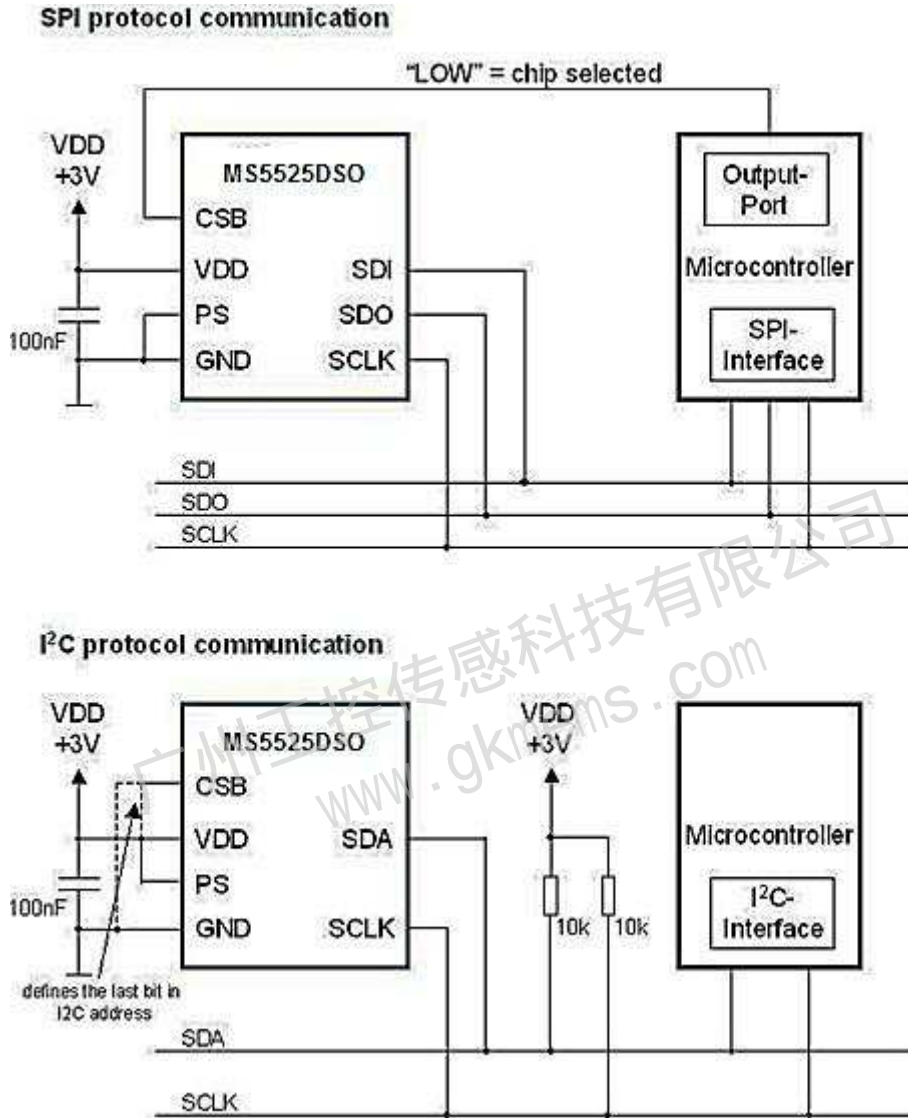

Note:

1. Place 100nF capacitor between Supply and GND to within 2cm of sensor

DIMENSIONS

MS5525DSO-DBxxxS

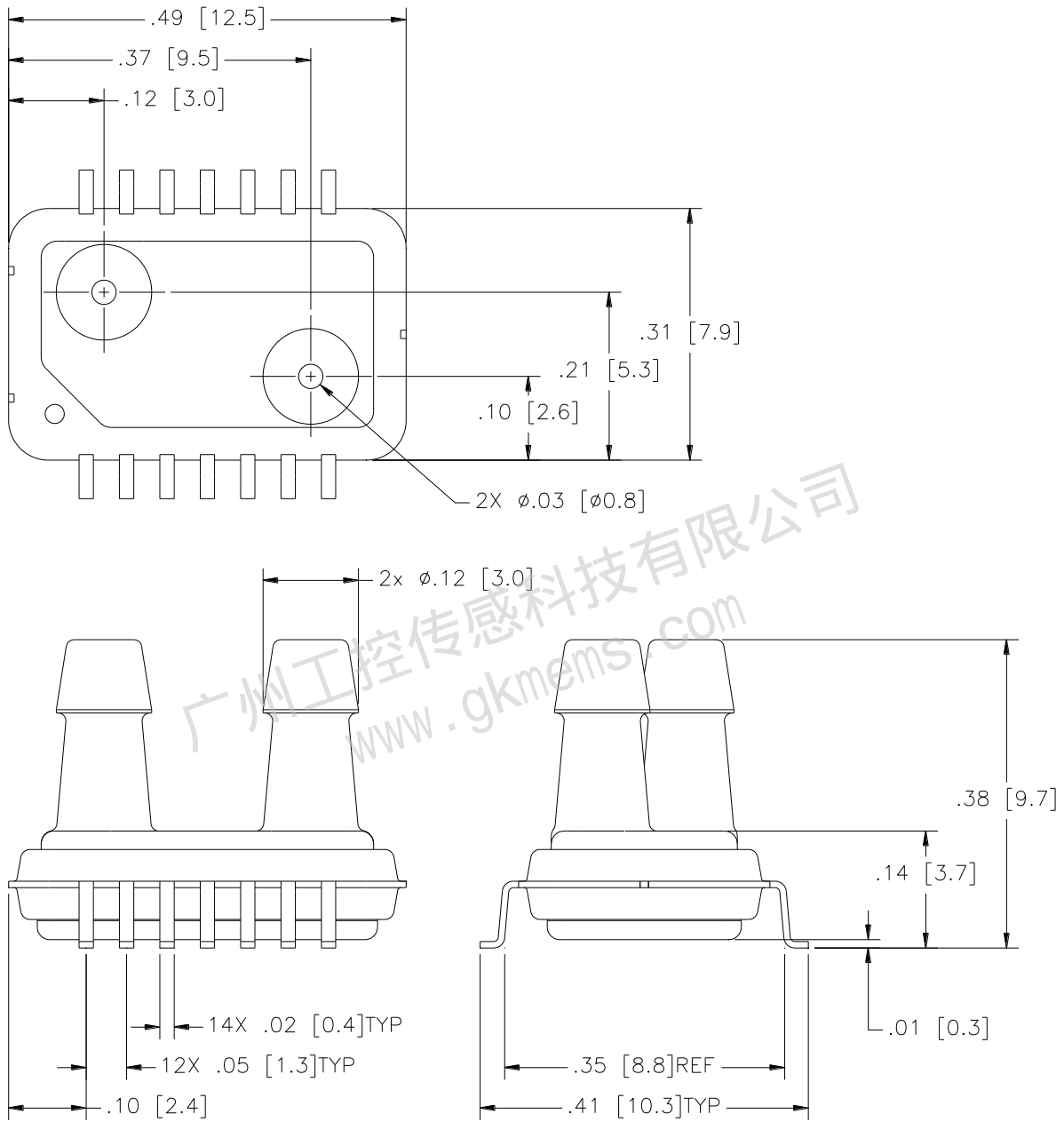

MS5525DSO-STxxxS

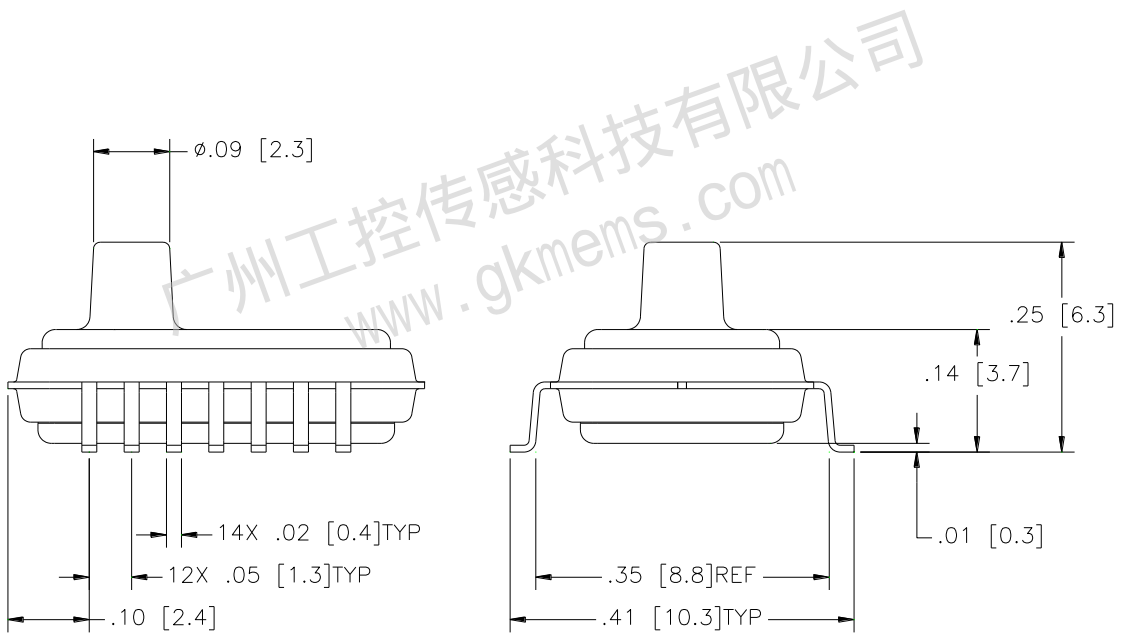
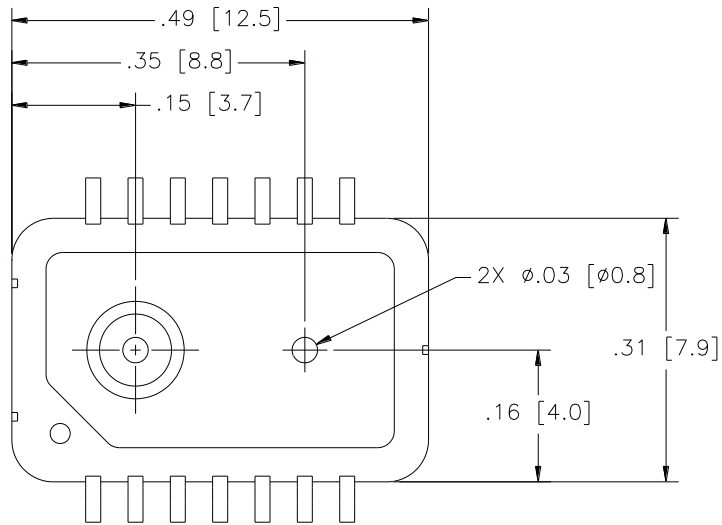

MS5525DSO-SBxxxS

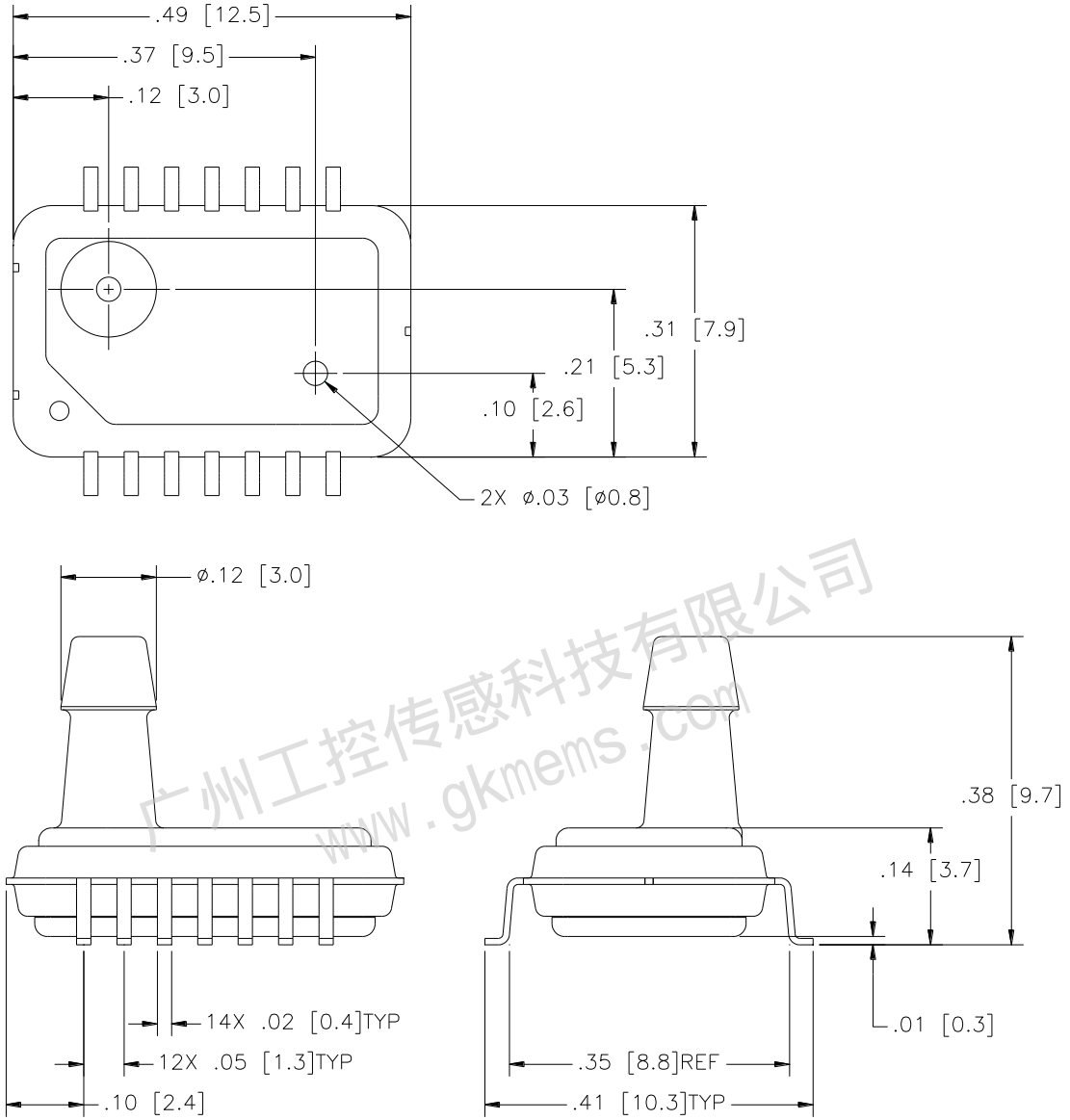

MS5525DSO-DHxxxS

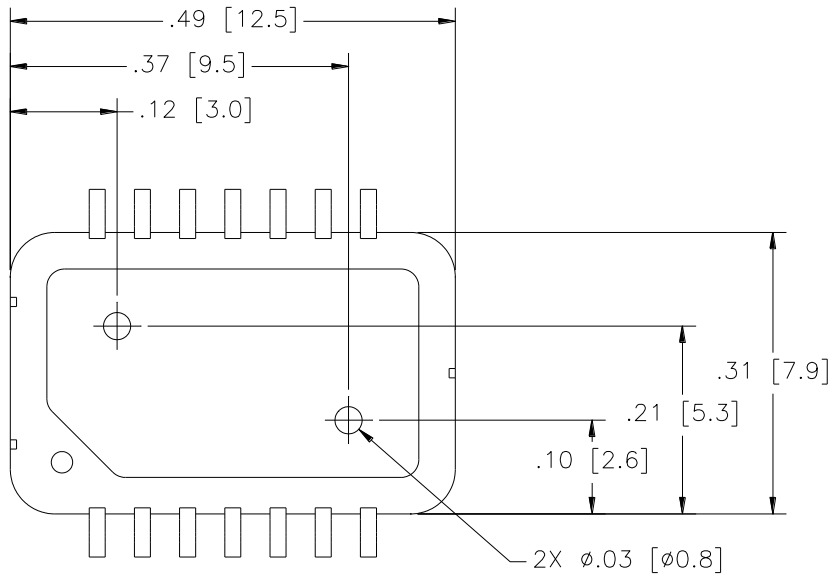

广州工控传感科技有限公司
www.gkmems.com

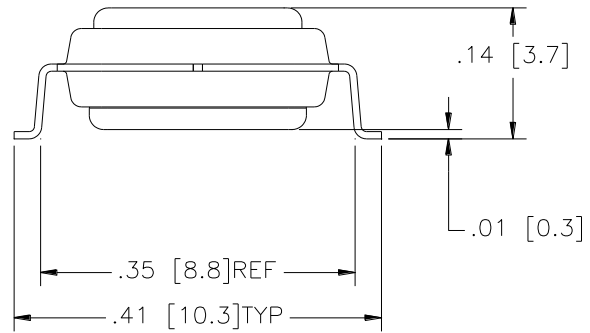
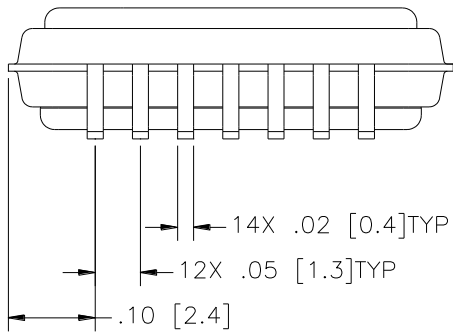

MS5525DSO-FTxxxS

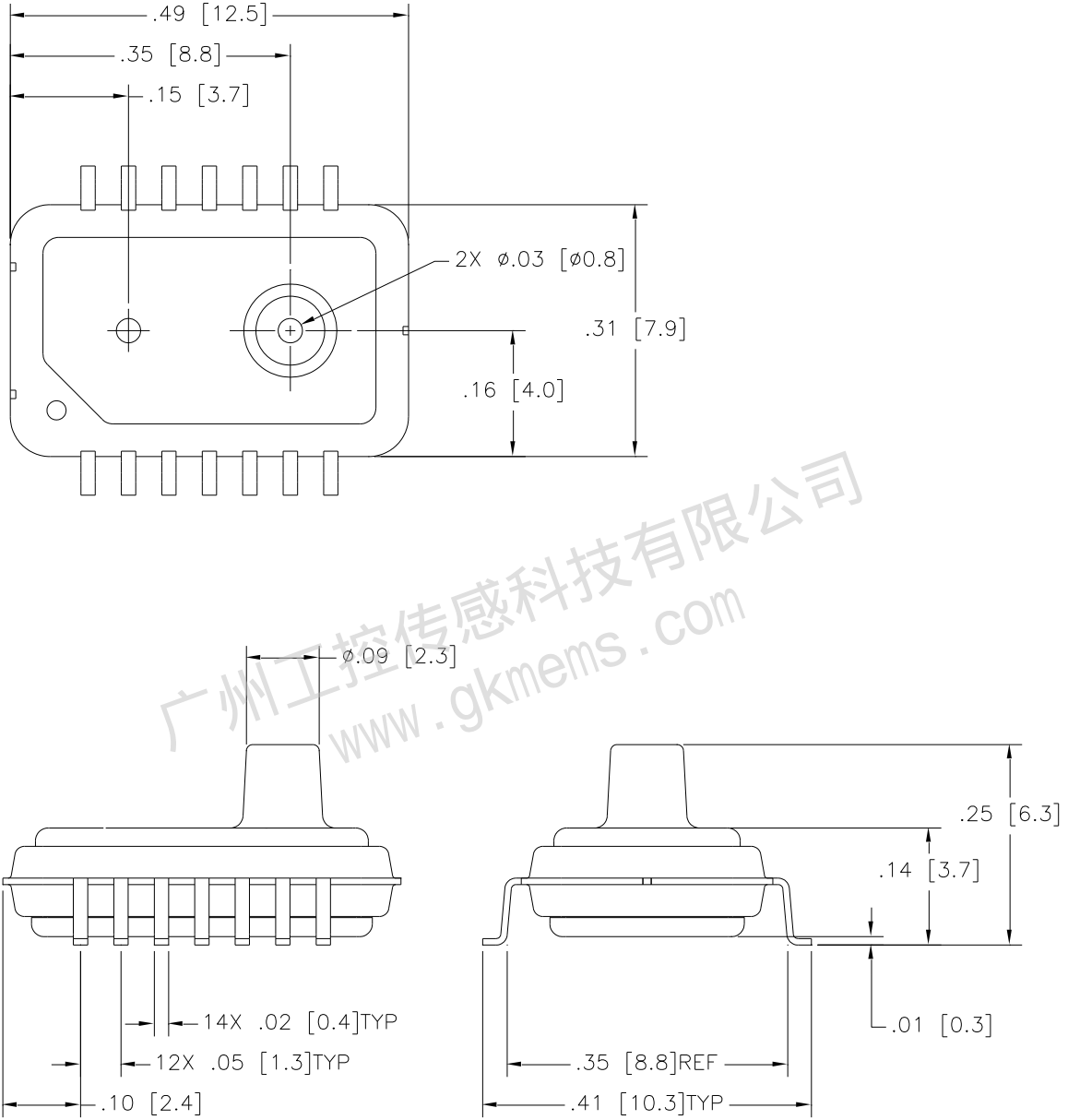

MS5525DSO-FBxxxS

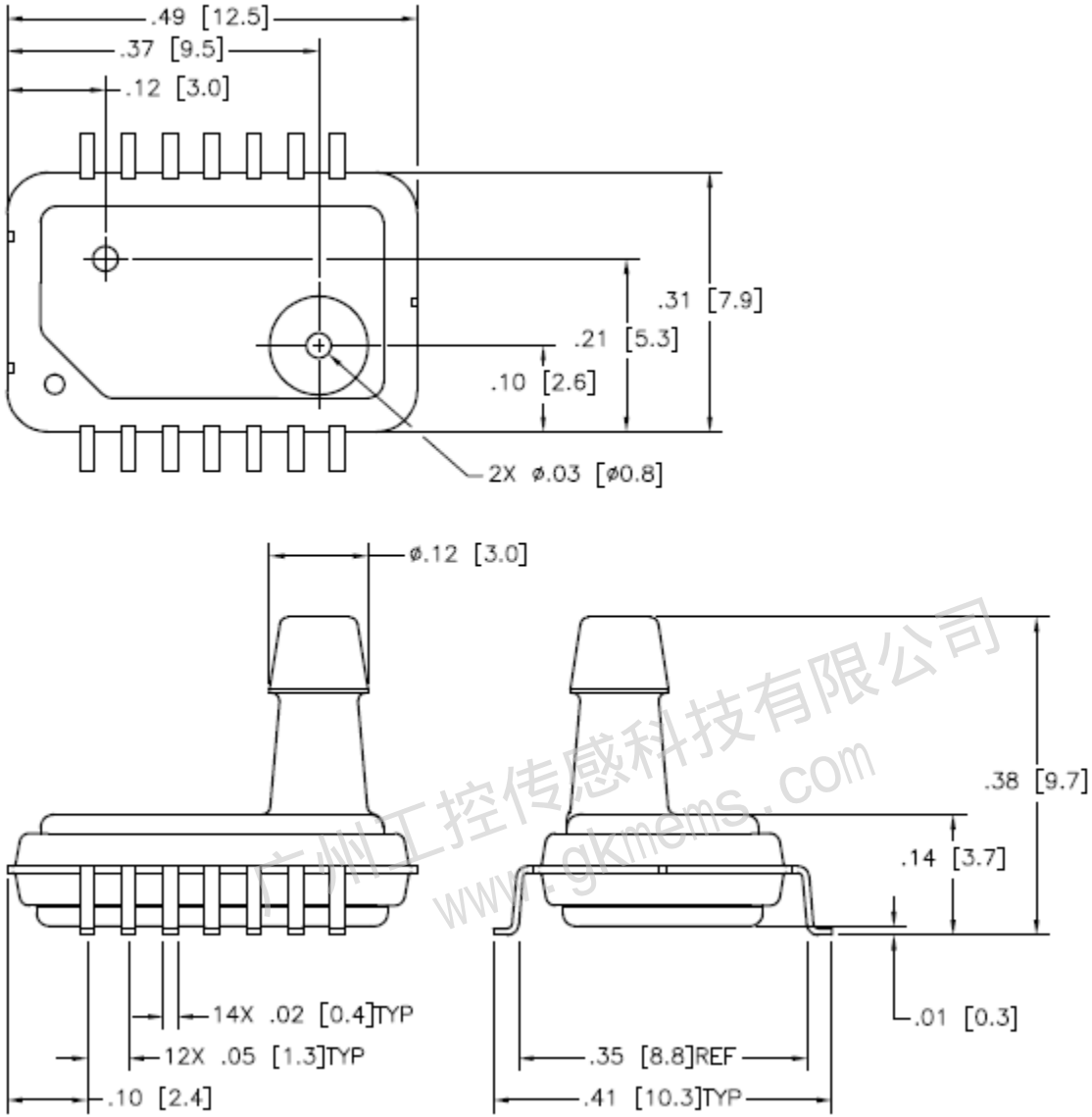

ORDERING INFORMATION

5525DSO – DB 005 G S

Package Style	
DB	Dual Barb
SB	Single Barb
ST	Single Tube
DH	Dual Hole
FT	Front Tube
FB	Front Single Barb

Pressure Range (psi)
001 ⁽¹⁾
002 ⁽²⁾
005 ⁽²⁾
015
030

⁽¹⁾Available only in Differential Pressure Type

⁽²⁾Available in Differential and Gauge Pressure Types

Pin Style	
S	Gull Wing

Pressure Type	
G	Gage
A	Absolute
D	Differential

广州工控传感科技有限公司
www.gkmems.com

广州工控传感科技有限公司

电话：400-822-6658

邮箱：gzgk@foxmail.com

网址：www.gkmems.com

地址：广州市天河区珠江西路15号16层