



GCD-SE SERIES

Single Ended DC Gage Heads

SPECIFICATIONS

- ◆ **Hermetically sealed housing**
- ◆ **Single ended 8.5 to 24VDC supply**
- ◆ **Low current consumption (only 6mA)**
- ◆ **Ideal for battery operation**
- ◆ **IEC IP68 rating to 1,000 PSI [70 bars]**
- ◆ **Long strokes up to 2 inches**
- ◆ **Hardened tool steel contact tip**
- ◆ **High side load resistance**

The GCD-SE Series of heavy-duty DC operated gage heads enable high performance in environments containing moisture, dirt, and fluid contaminants. With a spring loaded LVDT, a precision linear bearing, and internal conditioning electronics operating on a single ended 8.5 to 28VDC input with minimal current draw, the GCD-SE is ideally suited to portable measurement applications in difficult environments. Internal EMI, ESD and RFI protection, provide CE compliance when correctly installed. Synchronous demodulation ensures unsurpassed noise rejection.

These robust gage heads allow measurements over stroke ranges from 0 to 0.1 inch [2.54mm] up to 0 to 2 inches [50.8 mm]. The spring force is typically 9oz [255 grams] at fully compressed electrical stroke. A removable black-chromed, hardened tool steel tip is threaded (4-48UNF-2A) to the working end. Internal construction prevents the core and shaft from rotating as they move longitudinally. The integral electrical connector (welded) provides for easy installation and allows replacing a damaged cable without sacrificing the sensor. Installation and adjustment are facilitated by an external 1/2-20 mounting thread and the two locknuts supplied with each unit.

Like in most of our LVDTs, the GCD-SE windings are vacuum impregnated with a specially formulated, high temperature, flexible resin, and the coil assembly is potted inside its housing with a two-component epoxy. This provides excellent protection against hostile environments such as high vibration and shock.

The ruggedness, long life cycle, and very high reliability of the GCD-SE Series provide the lowest cost of ownership over the life of the equipment onto which they are installed. The one-piece front end (barrel which contains the bearing assembly), machined from solid stainless steel bar, coupled with a bronze bushing, has far greater resistance to bending forces and side loads compared to other designs. This is particularly important on the longer stroke versions; it reduces the common risk of probe damage/bending during installation or maintenance of industrial equipment. The GCD-SE Series designs also require fewer parts and weld joints, thereby increasing overall structural integrity and reliability.

FEATURES

- ◆ All-welded stainless steel construction
- ◆ Resistant to harsh environments
- ◆ MS type connector (MIL-C-5015)
- ◆ Long cycle life
- ◆ CE compliant
- ◆ Calibration certificate supplied with each unit
- ◆ Air extend/spring retract available (*consult factory*)

APPLICATIONS

- ◆ Roller Gap Control
- ◆ In-process Wet Grinding
- ◆ Hand Held Gages
- ◆ X-Y Positional Feedback
- ◆ Automotive chassis track testing
- ◆ Remote site monitoring

GCD-SE SERIES

Single Ended DC Gage Heads

PERFORMANCE SPECIFICATIONS

ELECTRICAL SPECIFICATIONS					
Parameter	GCD-SE 100	GCD-SE 250	GCD-SE 500	GCD-SE 1000	GCD-SE 2000
Stroke/gaging range	0 to 0.10 [2.54]	0 to 0.25 [6.35]	0 to 0.50 [12.7]	0 to 1 [25.4]	0 to 2 [50.8]
Sensitivity (VDC/inch)	50	20	10	5	2.5
Supply voltage	+8.5 to +28VDC				
Supply current	10mA maximum; 6mA typical				
Line regulation	0.2 mV/V				
Output voltage range	0 to +5VDC (4 wire); +1 to +6VDC (3 wire) - Increases when the core is displaced towards connector				
Output Impedance	1 Ohm				
Noise and ripple	10 mV RMS, maximum				
Non-linearity	±0.25% of FR, maximum				
Repeatability	25 μ-inch [0.6 μm]				
Stability	0.1% of FSO after warm up				
Temperature coefficient of sensitivity	0.028%/°F [0.05%/°C]				
Frequency response (dynamic)	15Hz, maximum				

ENVIRONMENTAL SPECIFICATIONS & MATERIALS	
Operating temperature	-13°F to +185°F [-25°C to 85°C]
Survival temperature	-65°F to +250°F [-55°C to 125°C]
Shock survival	250 g (11 ms half-sine)
Vibration tolerance	10 g up to 2kHz
Housing material	AISI 400 Series stainless steel
Electrical connector	6-pin MS type connector (MIL-C-5015)
IEC 60529 rating	IP68 to 1,000 PSI [70 bars] with use of proper mating connector plug

Notes:

All values are nominal unless otherwise noted

Dimensions are in inch [mm] unless otherwise noted

FR: Full Range is the stroke range, end to end; FR=S for a 0 to S stroke range

FSO (Full Scale Output): Largest absolute value of the outputs measured at the ends of the range

WIRING SCHEMATICS & BLOCK DIAGRAM

Important: NEVER connect Pins D and C together; NEVER connect Pin D to other GCD-SE's

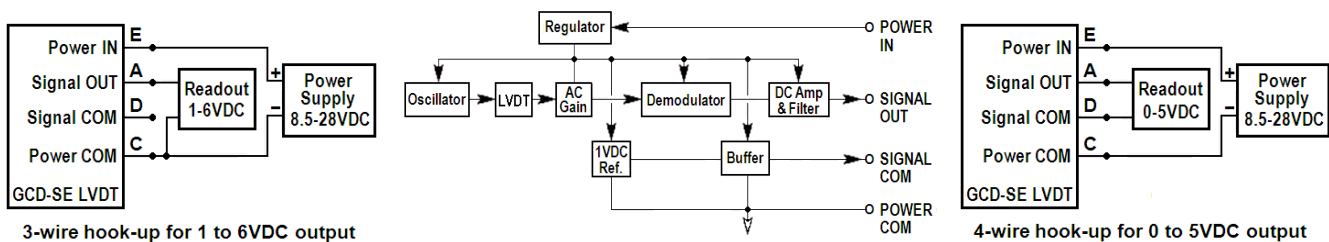

A through E: Connector pin assignments

GCD-SE SERIES

Single Ended DC Gage Heads

MECHANICAL SPECIFICATIONS

Parameter	GCD-SE 100	GCD-SE 250	GCD-SE 500	GCD-SE 1000	GCD-SE 2000
Stroke/gaging range	0.10 [2.5]	0.25 [6.4]	0.50 [12.7]	1 [25.4]	2 [50.8]
Pre-travel	0.15 [3.8]	0.25 [6.3]	0.04 [1.0]	0.20 [5.1]	0.10 [2.5]
Over-travel (minimum)	0.30 [7.6]	0.30 [7.6]	0.25 [6.3]	0.35 [8.9]	0.10 [2.5]
Main body length "A"	4.06 [103.1]	4.9 [124.5]	5.76 [146.3]	7.46 [189.5]	9.42 [239.3]
Overall body length "B"	5.42 [137.7]	6.27 [159.3]	7.13 [181.1]	10.45 [265.4]	12.41 [315.2]
Plunger length "C" (fully extended; 0 or 1 VDC out)	6.48 [164.6]	7.3 [185.4]	8.16 [207.3]	12.93 [328.4]	14.87 [377.7]
Weight (Ounce)	2.5 oz	3.3 oz	3.5 oz	5.5 oz	8.0 oz
Weight (Gram)	71 G	93 G	100 G	156 G	227 G
Spring force	Typically 9oz [255 grams] at fully compressed electrical stroke				

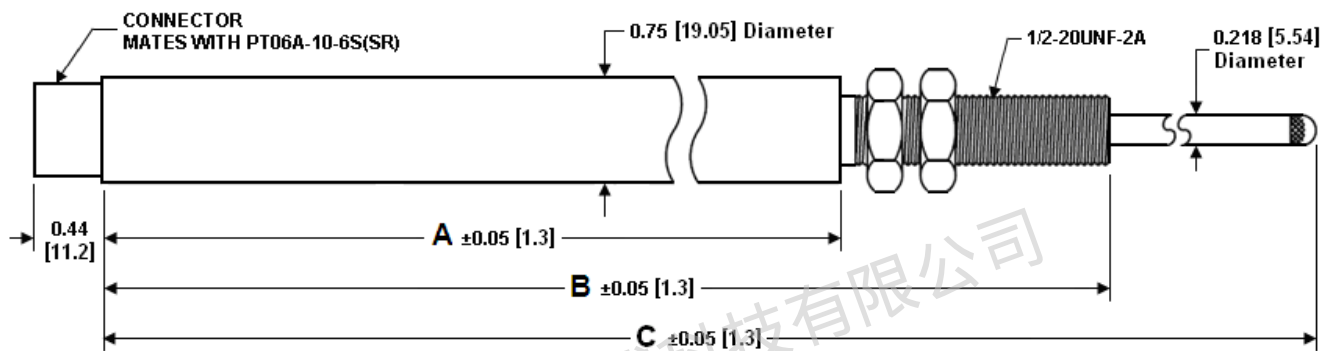

REPLACEMENT/OPTIONAL CONTACT TIPS

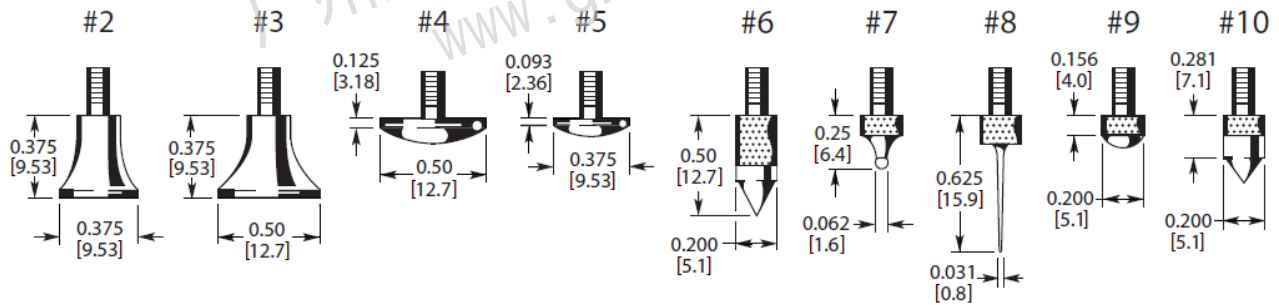

Dimensions are in inch [mm]

GCD-SE SERIES

Single Ended DC Gage Heads

ORDERING INFORMATION

Description	Model	Part Number
0.10 inch gage head	GCD-SE 100	02351006-000
0.25 inch gage head	GCD-SE 250	02351007-000
0.5 inch gage head	GCD-SE 500	02351008-000
1 inch gage head	GCD-SE 1000	02351009-000
2 inch gage head	GCD-SE 2000	02351010-000
OPTIONS		
Air extend/spring retract gage head <i>(Consult factory)</i>	All GC Series	XXXXXXXX-150

ACCESSORIES		
DC power supply (15VDC)	Model PSD 40-15	02291339-000
Mating connector kit	PT06A-10-6S(SR)	62101011-000
Cable with wired mating connector <i>(1)</i>	GCD-SE to Stripped & Tinned	04290589-000
Replacement contact tips	Contact Tip 2	67010005-000
	Contact Tip 3	67010006-000
	Contact Tip 4	67010002-000
	Contact Tip 5	67010007-000
	Contact Tip 6	67010008-000
	Contact Tip 7	67010009-000
	Contact Tip 8	67010010-000
	Contact Tip 9	67010001-000
	Contact Tip 10	67010011-000

(1) Cables are shielded, 10 foot long, and rated 80°C [176°F] operating. Consult factory for other lengths.

广州工控传感科技有限公司

电话: 400-822-6658

邮箱: gzgk@foxmail.com

网址: www.gkmems.com

地址: 广州市天河区珠江西路15号16层